

Main

Range of product	Modicon Power Supply
Product or component type	Power supply
Power supply type	Regulated switch mode
Variant option	Panel mount
Enclosure material	Aluminum
Nominal input voltage	100...240 V AC single phase
Input voltage limits	90...264 V AC
Rated power in W	100 W
Output voltage	24 V DC
Power supply output current	4.5 A

Complementary

Nominal network frequency	50...60 Hz
Network system compatibility	TN TT IT
Maximum leakage current	1 mA 240 V AC
Input protection type	Integrated fuse (not interchangeable) 4 A
Inrush current	45 A 115 V 85 A 230 V
Power factor	0.55 at 115 V AC 0.45 at 230 V AC
Efficiency	89 % 230 V AC
Output voltage adjustment	21.6...26.4 V
Power dissipation in W	20 W
Current consumption	< 2.3 A 115 V AC < 1.5 A 230 V AC
Turn-on time	< 500 ms

Disclaimer: This documentation is not intended as a substitute for and is not to be used for determining suitability or reliability of these products for specific user applications

Holding time	> 20 ms 115 V AC > 40 ms 230 V AC
Startup with capacitive loads	4000 µF
Residual ripple	< 150 mV
Expected capacitor life time	10 year(s)
Meantime between failure [MTBF]	700000 h at 77 °F (25 °C), full load conforming to SR 332
Output protection type	Against overload and short-circuits automatic reset Against over temperature manual reset Against overvoltage manual reset
Connections - terminals	Screw connection 0.75...2.5 mm ² , AWG 18...AWG 14) without wire end ferrule Screw connection 0.75...1.5 mm ² , AWG 18...AWG 16) with wire end ferrule
Line and load regulation	< 0.5 %line < 1 %load
Status LED	Output voltage 1 LED Green)
Depth	5.08 in (129 mm)
Height	1.18 in (30 mm)
Width	3.82 in (97 mm)
Net Weight	0.66 lb(US) (0.3 kg)
Output coupling	Parallel Serial
Mounting support	Top hat type TH35-15 rail IEC 60715 Top hat type TH35-7.5 rail IEC 60715 Double-profile DIN rail panel mounting
Supply	SELV EN/IEC 60950-1 SELV EN/IEC 60204-1 SELV IEC 60364-4-41

Environment

Standards	EN 62368-1 EN 61010-1 EN 61010-2-201 EN 61204-3 EN 61000-6-1 EN 61000-6-2 EN 61000-6-3 EN 61000-6-4 EN 61000-3-2 EN 61000-3-3 UL 62368-1 UL 61010-1 UL 61010-2-201 CSA C22.2 No 62368-1 CSA C22.2 No 61010-1 CSA C22.2 No 61010-2-201 EN/IEC 62368-1
Product certifications	CE CULus EAC RCM CB Scheme KC
Environmental characteristic	3M4 IEC 60721-3-3
Operating altitude	5000 m
Shock resistance	100 m/s ² 11 ms
IP degree of protection	IP10
Ambient air temperature for operation	-22...158 °F (-30...70 °C)
Ambient air temperature for storage	-40...185 °F (-40...85 °C)
Relative humidity	0...95 % without condensation
Overvoltage category	II
Electrical energy source class conforming to IEC 62368-1	ES1

Electrical shock protection class	Class I
Pollution degree	2
Vibration resistance	3 mm 2...9 Hz)IEC 60068-2-6 10 m/s ² 9...200 Hz)IEC 60068-2-6
Electromagnetic immunity	Immunity to electrostatic discharge 6 kV contact discharge) EN/IEC 61000-4-2 Immunity to electrostatic discharge 9 kV air discharge) EN/IEC 61000-4-2 Immunity to conducted RF disturbances 10 V/m 80 MHz...2 GHz) EN/IEC 61000-4-3 Immunity to conducted RF disturbances 5 V/m 2...2.7 GHz) EN/IEC 61000-4-3 Immunity to conducted RF disturbances 3 V/m 2.7...6 GHz) EN/IEC 61000-4-3 Immunity to fast transients 4 kV on input-output) EN/IEC 61000-4-4 Surge immunity test 3 kV between power supply and earth) EN/IEC 61000-4-5 Surge immunity test 1.5 kV between phases) EN/IEC 61000-4-5 Immunity to conducted RF disturbances 10 V 0.15...80 MHz) EN/IEC 61000-4-6 Immunity to magnetic fields 30 A/m 50...60 Hz) EN/IEC 61000-4-8 Immunity to voltage dips EN/IEC 61000-4-11 Disturbing field emission EN 55016-2-3 Limits for harmonic current emissions EN 61000-3-2 Conducted disturbance emission EN 55016-1-2 Conducted disturbance emission EN 55016-2-1
Electromagnetic emission	Conducted emissions EN 61000-6-3 Radiated emissions EN 61000-6-4
Dielectric strength	3750 V AC input to output

Ordering and shipping details

GTIN	03606481500281
------	----------------

Offer Sustainability

Sustainable offer status	Green Premium product
California proposition 65	WARNING: This product can expose you to chemicals including: Lead and lead compounds, which is known to the State of California to cause cancer and birth defects or other reproductive harm. For more information go to www.P65Warnings.ca.gov
REACH Regulation	REACH Declaration
EU RoHS Directive	Pro-active compliance (Product out of EU RoHS legal scope) EU RoHS Declaration
Mercury free	Yes
RoHS exemption information	Yes
China RoHS Regulation	China RoHS declaration
Environmental Disclosure	Product Environmental Profile
Circularity Profile	End of Life Information
WEEE	The product must be disposed on European Union markets following specific waste collection and never end up in rubbish bins.

Electrical Safety

- If the unit is use in a manner not specified by the manufacturer, the protection provided by the equipment may be impaired.
- For means of disconnection a switch or circuit breaker, located near the product, must be included in the installation. A marking as disconnecting device for t
- The device has an internal fuse. The unit is tested and approved with branch circuit protective device up to 20A. This circuit breaker can be used as disconn
- The power supply is only suitable for audio, video, information, communication, industrial and control equipment.

Dimensions

Front and Side Views

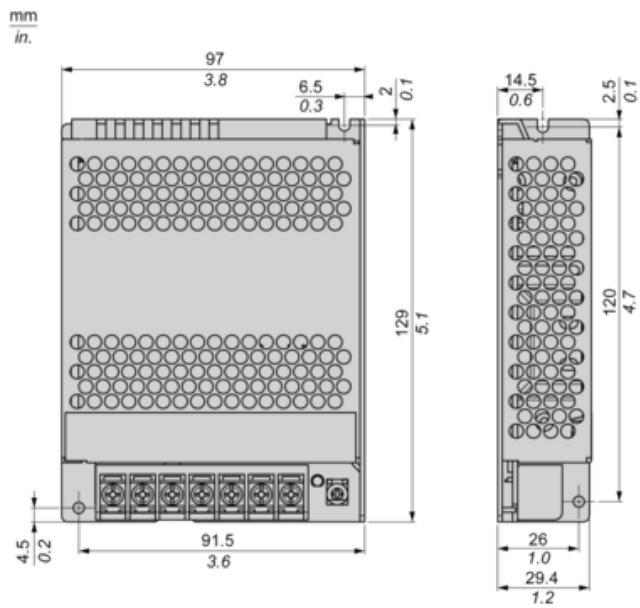

Connections and Schema

Correct Parallel Connection

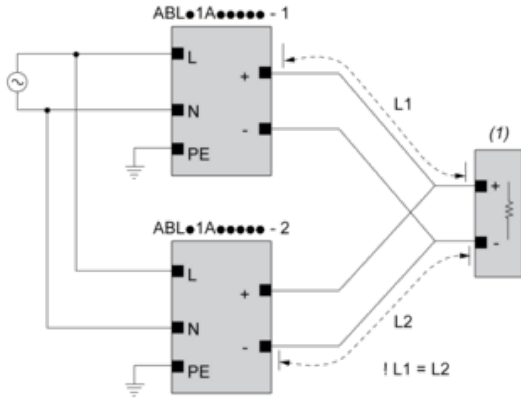

(1) : Load

Incorrect Parallel Connection

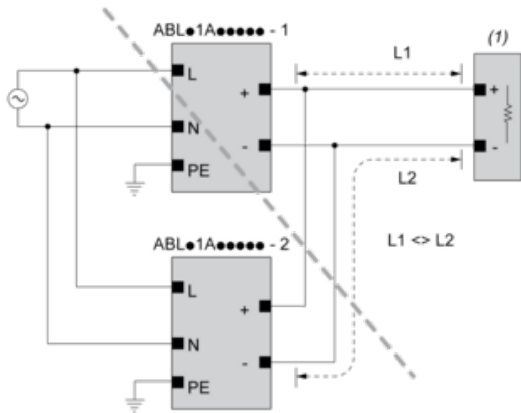

(1) : Load

ABLx1Axxxxx-1 = ABLx1Axxxxx-2

max 2 x ABLx1Axxxxx

L1 = L2

ΔV max 25 mV

$L_{Load} < 90\% \cdot 2 \cdot L_{nom}$

Output Voltage Balancing

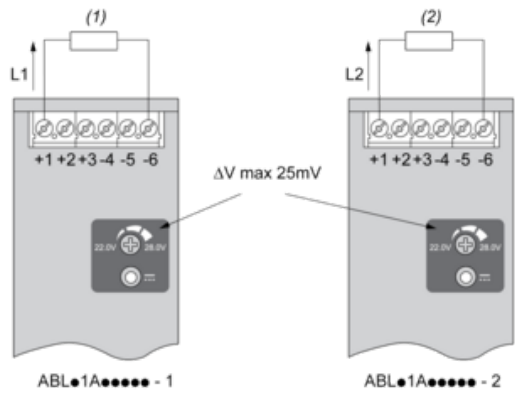

(1) : R_{Load1}

(2) : R_{Load2}

$R_{Load1} = R_{Load2}$

$I_1 = I_2 = \sim I_{nom}$

Series Connection

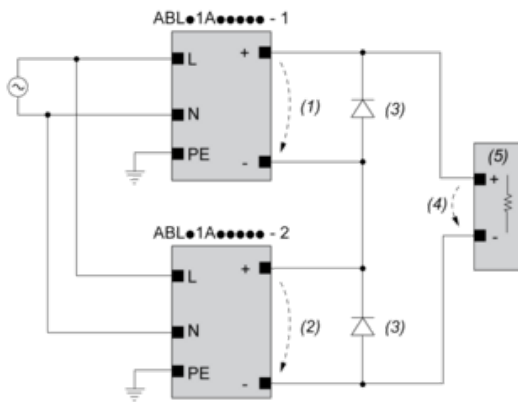

(1) : V_{out1}

(2) : V_{out2}

(3) : 2 x Diode, $V_{RRM} > 2 \times V_{out1/2}$, $I_F > 2 \times I_{nom1/2}$

(4) : $V_{Load} = 2 \times V_{out}$

(5) : Load

Connections and Schema

	(1)		
	<40°C	<50°C	<70°C
ABLP1A12085	60°C	70°C	90°C
ABLP1A24045	60°C	70°C	90°C
ABLP1A24062	60°C	70°C	90°C
ABLP1A24100	60°C	70°C	90°C

(1) : Ambient

Performance Curves

Mounting Position A, B, F and G

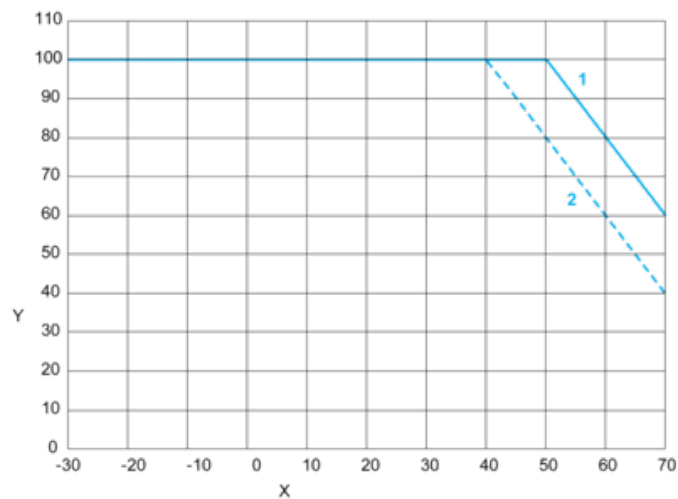

Mounting Position C

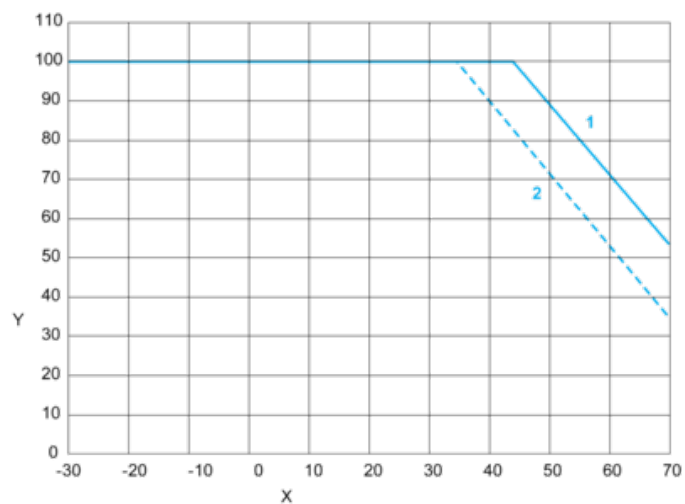

Mounting Position H

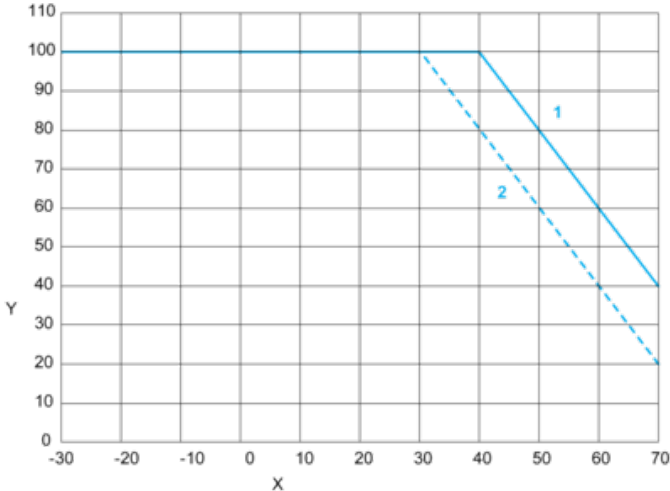

X : Surrounding Air Temperature

Y : Percentage of Max Load (%)

1 : Altitude 2000 m

2 : Altitude 5000 m

Note : < 115 VAC additional derating by 0.6% / V

Mounting

Mounting Position A

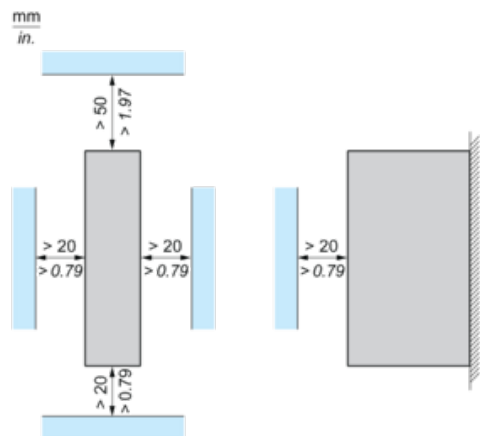

Mounting Position B

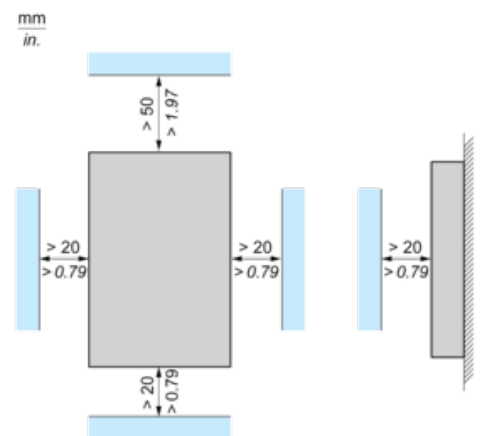

Mounting Position C

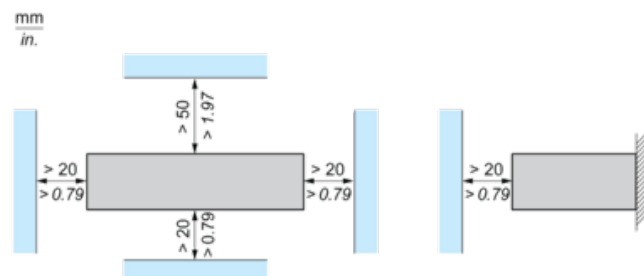

Mounting Position F

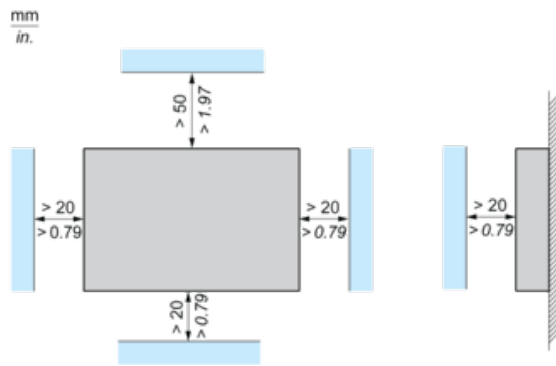

Mounting Position G

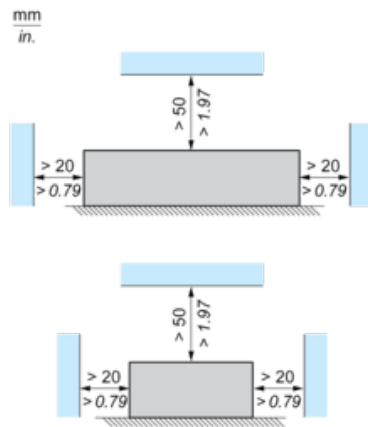

Mounting Position H

